

General Description

Module Z-SG is a strain gauge signal converter. Measurements taken using the 6-wires or 4-wires technique are available through Modbus-RTU serial protocol or the analog output. The module is also characterised by:

- Facilitated power supply and serial bus wiring by means of the bus housed in the DIN rail.
- Communication configurability by DIP-switch or software.
- RS485 serial communication with MODBUS RTU protocol, maximum 32 nodes.
- Protection against ESD discharge up to 4 kV.
- Insulation 1500 Vac between input and all the other circuits, between communication and power supply and between analog output and power supply.
- Analog output in voltage or current, with settable limits.
- Strain gauge calibration with standard weight.
- Strain gauge calibration not required if the sensitivity of the strain gauge is known.
- Configurable digital I/O.
- Rejection at 50 and 60Hz.
- Configurable Resolution.
- Sampling frequency settable from 12,53 Hz to 151,71 Hz.
- Stable weight indication via Modbus register/digital output.
- Remote writing of the tare in volatile and/or non-volatile memory by digital input/Modbus register/Modbus commands.
- Strain gauge directly powered by instrument.
- Ratiometric measurement.
- Sensitivity from ± 1 to ± 64 mV/V, settable by DIP-switch for integer values, via software for real/integer values.
- Alarm generated when programmable threshold is exceeded.
- Measurement stabilisation through the calculation of the moving average value of a programmable number of samplings.
- Complete configurability by EASY SETUP software.

Technical Specifications

Power supply :	10 - 40 Vdc or 19 - 28 Vac (50..60 Hz)
Consumption :	max 2.0 W
Communication Ports :	-Rs485, 2400 - 115200 Baud. -RS232, 2400 Baud, Address: 01, Parity: NO, Data: 8 bits, Stop bits: 1.
Protocol :	MODBUS-RTU

Analog Input

Input Type :	6-wires or 4-wires differential measurement input.
Input impedance	>1M Ω
Full scale :	± 5 mV - ± 320 mV
Error :	Calibration : 0,01 % of the full scale value. Linearity : 0,01 % of the full scale value. Thermal Stability : 0,0025 % / $^{\circ}$ C of the full scale value.
Insulation :	1500 Vac respect to the remaining circuits.

Strain gauge characteristics

Power supply voltage :	5 Vdc
Minimum impedance :	87 Ω equivalent (derived from several strain gauges connected in parallel).
Sensitivity :	From ± 1 mV/V to ± 64 mV/V.
Terminals :	4 or 6.

Analog Output

Output Voltage :	0 - 10 Vdc, 0 - 5 Vdc, minimum load resistance : 2 k Ω .
Output Current :	0 - 20 mA, 4 - 20 mA, max load resistance: 500 Ω .
Transmission error :	0,1 % (max. range).
Response time (10%..90%) :	5 ms.

Digital Input or Output (as alternative)

Optoisolated digital Input :	Max Voltage : 30 V.
Optoisolated digital Output :	Max Current : 50 mA, Max Voltage : 30 V.

Other Features

ADC :	24 bit.
Thermal drift :	25 ppm/K.
Sampling frequency :	settable from 12,53 Hz to 151,71 Hz.
Interference rejection :	settable at either 50 Hz or 60 Hz.
Insulation voltage :	1500 Vac between the measurement input and all the other circuits. 1500 Vac between power supply and communication. 1500 Vac between power supply and analog output.
Protection :	IP20
Environmental conditions :	Temperature -10 - +65 °C. Humidity 30 - 90 % non-condensing. Altitude: up to 2000 m a.s.l.
Storage temperature :	-20 - +85 °C
Signalling by LED :	Power supply, calibration, RS485 communication.
Connections :	-Removable 3-way screw terminals, 5,08 mm pitch. -Rear IDC10 connector for DIN rail. -3.5 mm stereophonic front jack for RS232 (COM) connection. -Lateral button for strain gauge calibration.
Box :	PBT, black
Dimensions and weight :	100 x 112 x 17,5 mm, 140 g.
Reference standards :	EN61000-6-4 (electromagnetic emission, industrial environment) EN61000-6-2 (electromagnetic immunity, industrial environment) EN61010-1 (safety).



MODULE Z-SG CALIBRATION

The calibration procedures are illustrated in detail on the appropriate attached addendum. Anyway they are briefly listed below.

Calibration Mode 1

The user has at his disposal a PC with EASY SETUP software (to download from www.seneca.it web site) and a weight of known value. It is not necessary that the known weight is equal to the full scale of the strain gauge or to the full scale of the measurement.

Calibration Mode 2

The user has at his disposal a PC with EASY SETUP software and a strain gauge with declared sensitivity.

Calibration Mode 3

The user does not have at his disposal a PC but has a weight of known value equal to the full scale of measurement.

Calibration Mode 4

The user does not have at his disposal a PC and a weight of known value but has only a strain gauge with declared sensitivity.

Frontal Panel and Leds

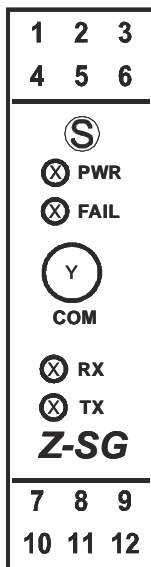

DIP-switch Position Lateral button for calibration

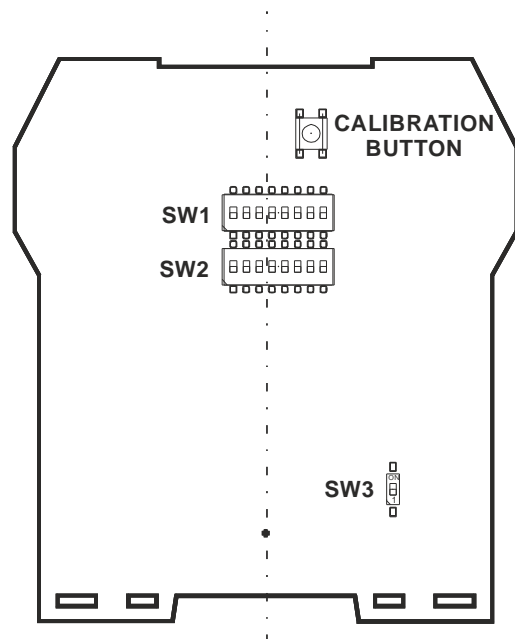

To use the lateral button for calibration, move to OFF position the DIP-switch 1 of SW2.

DESCRIPTION OF OPERATION

The strain gauge's measured value is translated into an analog output signal (current or voltage). The measurement of the input is available through Modbus RTU protocol upon query by RS485 bus and/or RS232 jack.

Serial communication parameter settings can be made either by Modbus RTU or DIP-switch, whereas the settings selectable via SW2 cannot be configured via Modbus (except the sensitivity).

The instrument's various functions are described below.

Stable Weight Function

The ***Stable Weight*** function informs the user of the precise moment in which weight has stabilised.

This information is available via Modbus register (see the **Modbus Registers** section, Register 40066: STATUS) and can also be signalled by digital output (after previous selection and programming by Modbus). This function is characterised by the two parameters: Δ Weight and Δ Time. The weight is considered stable whenever the net weight in the Δ Time has changed by a quantity lower than Δ Weight.

Digital input/output

The instrument offers the possibility to select either a digital input or a digital output. This selection (input or output) is made only by DIP-switch.

Digital Input: allows to memorize the tare during all the calibration phases and may be used as an alternative to the lateral button.

On the normal functioning it may be used to acquire the temporary tare, which will be lost at the turn off of the module; at the next start up the tare value, acquired on calibration, will be loaded.

Digital Output: the output can be configured via Modbus for three different operating modes and switches to ON or OFF status (always according to Modbus setting) whenever:

- 1)The Gross Weight exceeds the Full Scale of the strain gauge (Default Setting).
- 2)The Weight is stable and the Net Weight exceeds the threshold set.
- 3)The Weight is stable.

Analog Output

The analog output permits the retransmission of the net weight as follows:

- If the Net Weight in units of weight $\#$ **MINOUT**, the output relays 0%.
- If the Net Weight in units of weight \exists **MAXOUT**, the output relays 100%.
- At intermediate values, the progression is linear.

Where **MINOUT** and **MAXOUT** in Mode 1 and 2 may be set via MODBUS (The default values are respectively: 0,00 and 10000,00).

Rejection at 50 and 60 Hz

Rejection to interference at both 60 and 50 Hz can be enabled at the same time.

See **Appendix A** for details on setting and optimisation.

Calculation of Measurement Moving Average

The moving average of a settable number of samples (NR_SAMPLINGS: 1 ..100) can be calculated. In this way, the Net Weight displayed is the calculated moving average value. For Mode 1 and 2, NR_SAMPLINGS may be set via MODBUS (default: 100).

Installation rules

The module is designed to be installed in vertical position on a DIN 46277 rail. In order to ensure optimum performance and the longest working life, the module(s) must be supplied adequate ventilation and no raceways or other objects that obstruct the ventilation slots. Never install modules above sources of heat; we recommend installation in the lower part of the control panel.

Electric connections

RS485 SERIAL PORT AND POWER SUPPLY

The electric connections for power supply can be made by using either the terminals or the bus for the Seneca DIN rail. The RS485 bus connections are available only by using the bus for the DIN rail.

Power Supply from terminals

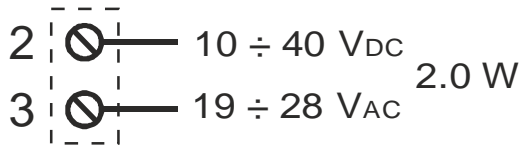

Bus connector for DIN rail connections

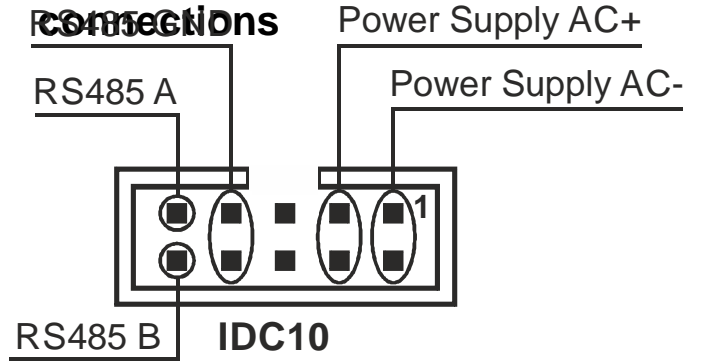

There is no insulation between RS485 and the analog output.

RS232 SERIAL PORT

Connection cable DB9 with a 3.5 mm stereo Jack, can be assembled as indicated in the following figure, or can be bought as an accessory.

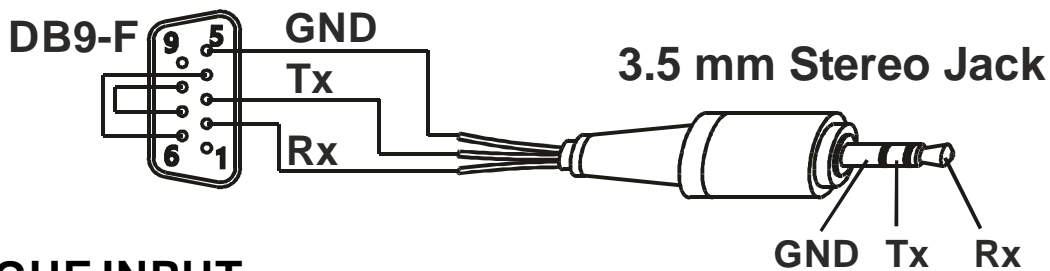

ANALOGUE INPUT

The figure below shows the connections to be made for connection to a strain gauge. The terminals have the following meaning:

- 7: Strain gauge positive power supply
- 8: Strain gauge positive power supply reading
- 9: Strain gauge positive reading
- 10: Strain gauge negative power supply
- 11: Strain gauge negative power supply reading
- 12: Strain gauge negative reading

The use of shield cables is necessary for the electronic connections.

6 wires measurement

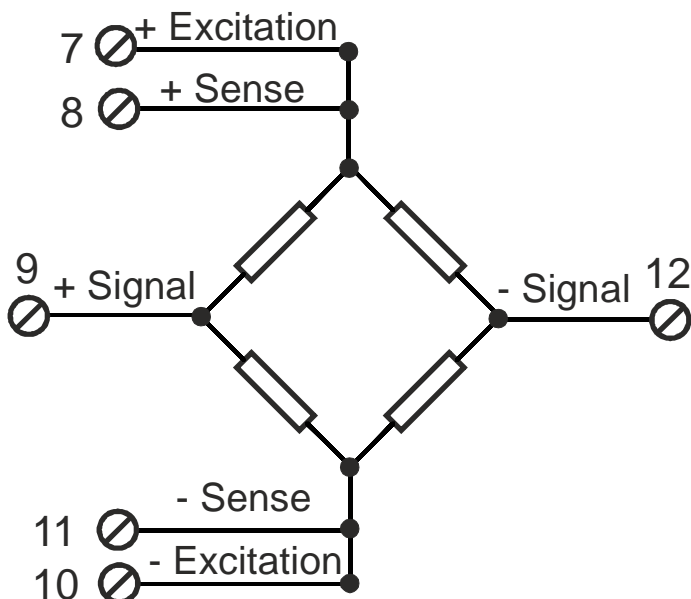

4 wires measurement

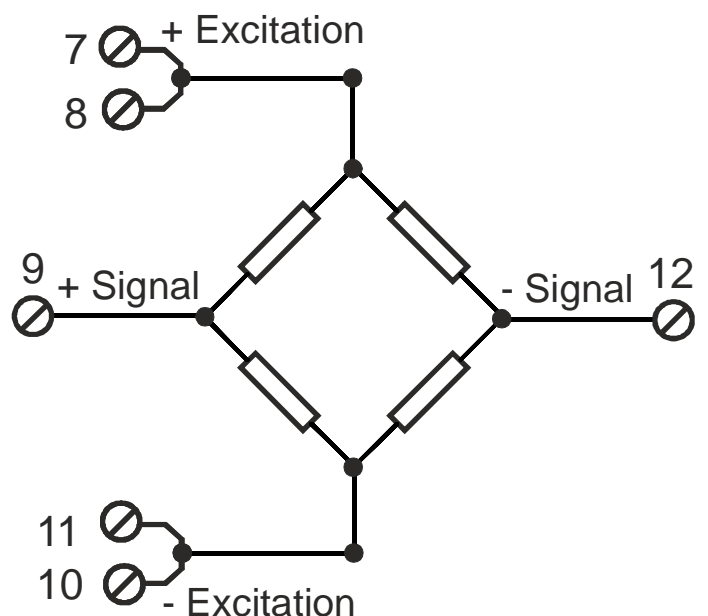

ANALOG OUTPUT

The module provides an analog output in voltage (0 - 10 VDC, 0 - 5 VDC) or current (0 - 20 mA, 4 - 20 mA). We recommend using shielded cables for the electric connections above.

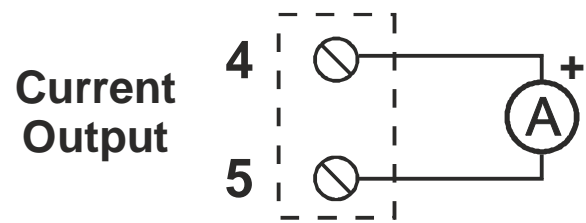
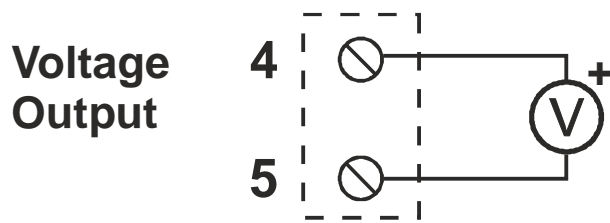

There is no insulation between RS485 and the analog output.

DIGITAL INPUT/OUTPUT

The module can be set to provide either a digital input or digital output. The connections in the two cases are as follows:

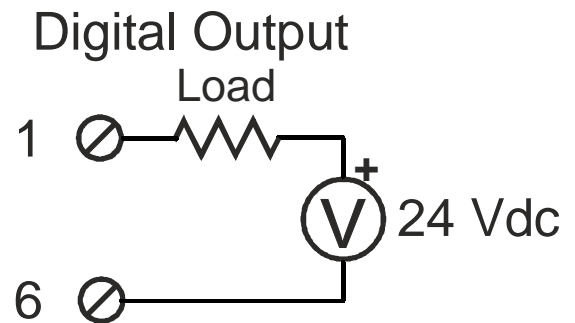
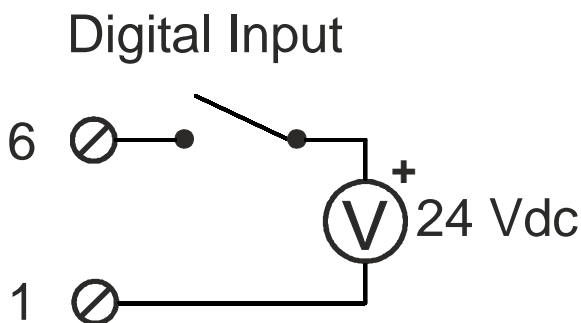

INDICATIONS BY LED ON THE FRONTAL PANEL

PWR LED (GREEN)	Meaning
Steady	Power supply is present.
ERR LED (YELLOW)	Meaning
Steady/Flashing	Signallings relative to the calibration phases. For further informations see the Calibration Addendum , containing the calibration procedures.
RX LED (RED)	Meaning
Steady	Data are being received through the RS485 communication port.
TX LED (RED)	Meaning
Steady	Data are being transmitted through the RS485 communication port.

SERIAL INTERFACE

For detailed information on RS485 serial interface, consult the documentation provided by the website www.seneca.it, in the section **Prodotti/Serie Z-PC/MODBUS TUTORIAL**.

DIP-SWITCH SETTING

The settings of the DIP-switches define the module's communication parameters (address and speed) and other parameters we are going to explain. In order for the setting modifications made to be confirmed valid, the module must be switched off and on again.

In all the following tables, the indication ● corresponds to a DIP-switch set in ON; no indication is provided when the DIP-switch is set in OFF.

COMMUNICATION SPEED (BAUDRATE)			
SW1	1	2	
			9600 Baud
	●		19200 Baud
	●		38400 Baud
	●	●	57600 Baud

ADDRESS							
SW1	3	4	5	6	7	8	
							Communication Parameters from EEPROM (*)
						●	Fixed Address: 01
					●		Fixed Address: 02
				●	●		Fixed Address: 03
			●				Fixed Address: 04
	X	X	X	X	X	X	Fixed Address, as from binary representation.
	●	●	●	●	●	●	Fixed Address: 63

DIGITAL I/O SELECTION - ENABLING LATERAL BUTTON OF CALIBRATION	
SW2	1
	Digital Input. Besides it enables the lateral button of calibration (**).
	● Digital Output

OUTPUT		
SW2	2	3
		0 - 10 V
	●	0 - 5 V
	●	0 - 20 mA
	●	● 4 - 20 mA

UTILIZE / CALIBRATION MODE (**)		
SW2	4	5
		Modes 2 and 4 are selected.
	●	Modes 1 and 3 are selected.
	●	The tare value acquired by the lateral button or digital input is saved on non-volatile memory (for Modes 2 and 4).
	●	● Manual calibration of the strain gauge (for Modes 1 and 3).

(*) The default configuration is the following: Address 1, 38400, no parity, 1 stop bit.

(**) For further informations consult the **Calibration Addendum**, containing the calibration procedures.

STRAIN GAUGE SENSITIVITY			
SW2	6	7	8
			± 1 mV/V
		●	± 2 mV/V
	●		± 4 mV/V
	●	●	± 8 mV/V
●			± 16 mV/V
●		●	± 32 mV/V
●	●		± 64 mV/V
●	●	●	Sensitivity from MODBUS register SENSE_RATIO (40044). Real values (not only integer) may be set too.

RS485 TERMINATOR	
SW3	1
	Terminator OFF
●	Terminator ON

PROGRAMMING

The EASY SETUP software should be used to programming/configuration. This software may be downloaded from the web site www.seneca.it.

During initial programming, the EEPROM (SW3 ..8 in OFF position) default setting values originally programmed as follows can be used:

Address = 1, SPEED = 38400 baud, PARITY = none, BIT NUMBER = 8, STOP BIT = 1.

The module can also be programmed through the front connector (COM) while paying attention to set the following connection parameters:

Address = 1, Speed = 2400 Baud, PARITY = none, STOP BIT = 1.

The Com communication port behaves in the same way as the RS485 bus port except for the communication parameters described above. It also has priority over the RS485 serial port and closes after 10 seconds of inactivity.



Disposal of Electrical & Electronic Equipment (Applicable throughout the European Union and other European countries with separate collection programs)

This symbol, found on your product or on its packaging, indicates that this product should not be treated as household waste when you wish to dispose of it. Instead, it should be handed over to an applicable collection point for the recycling of electrical and electronic equipment. By ensuring this product is disposed of correctly, you will help prevent potential negative consequences to the environment and human health, which could otherwise be caused by inappropriate disposal of this product. The recycling of materials will help to conserve natural resources. For more detailed information about the recycling of this product, please contact your local city office, waste disposal service or the retail store where you purchased this product.



SENECA s.r.l.

Via Austria, 26 - 35127 - PADOVA - ITALY

Tel. +39.049.8705355 - 8705359 - Fax +39.049.8706287

e-mail: info@seneca.it - www.seneca.it