

# Multifunction time relay

80 02 0 230 0000

## Instruction Manual



### General

#### Applications

- Multifunction time relay can be used for electrical appliances, control of lights, heating, motors, pumps and fans (10 functions, 10 time ranges, multi-voltage).

#### Function Features

- 10 functions: - 5 time functions controlled by supply voltage  
- 4 time functions controlled by control input  
- 1 function of latching relay

- Comfortable and well-arranged function and time-range setting by rotary switches.

- Time scale 0.1 s - 10 days divided into 10 ranges.

- Relay status is indicated by LED.

- 1-MODULE, DIN mounting.

### Technical parameters

Technical parameters	
Function	A,B,C,D,E,F,G,H,I,J
Supply terminals	A1-A2
Voltage range	AC/DC 12-240V(50-60Hz)
Burden	AC 0.09-3VA/DC 0.05-1.7W
Supply voltage tolerance	-15%;+10%
Supply indication	green LED
Time ranges	0.1s-10days,ON,OFF
Time setting	potentionmeter
Time deviation	10%-mechanical setting
Repeat accuracy	0.2%-set value stability
Temperature coecient	0.05% / ,at=20 (0.05% at=68 )
Output	2x SPDT
Current rating	16A/AC1
Switching voltage	250VAC/24VDC
Min.breaking capacity DC	500mW
Output indication	red LED
Mechanical life	$1 \times 10^7$
Electrical life(AC1)	$1 \times 10^5$
Reset time	max.200ms
Operating temperature	-20 to +55 -4 to 131
Storage temperature	-35 to +75 -22 to 158
Mounting/DIN rail	Din rail EN/IEC 60715
Protection degree	IP40 for front panel/IP20 terminals
Operating position	any
Overvoltage cathegory	III.
Pollution degree	2
Max.cable size(mm <sup>2</sup> )	solid wire max.1x 2.5or 2x 1.5/with sleeve max.1x 2.5(AWG 12)
Tightening torque	0.4Nm
Dimensions	90x 18x 64mm
Weight	82g
Standards	EN 61812-1,IEC60947-5-1

### Panel Diagram

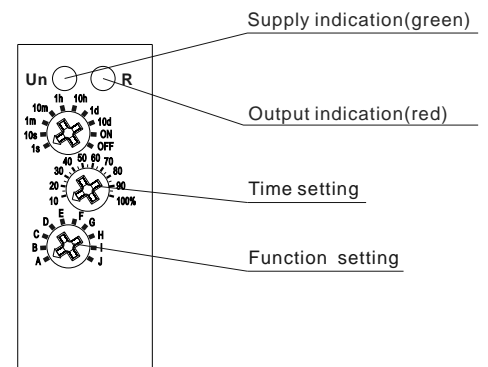

### Wiring Diagram

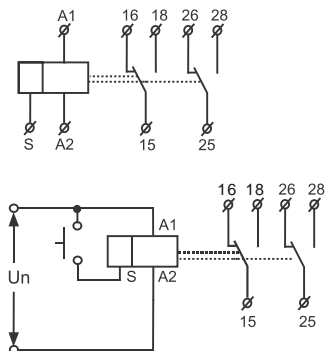

# Functions Diagram

## A: On Delay (Power On)

When the input voltage U is applied, timing delay t begins. Relay contacts R change state after time delay is complete. Contacts R return to their shelf state when input voltage U is removed. Trigger switch is not used in this function.

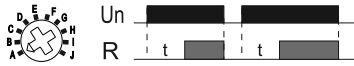

## B: Interval (Power On)

When input voltage U is applied, relay contacts R change state immediately and timing cycle begins. When time delay is complete, contacts return to shelf state. When input voltage U is removed, contacts will also return to their shelf state. Trigger switch is not used in this function.

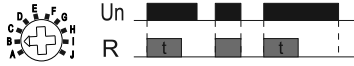

## C: Repeat Cycle (Starting Off)

When input voltage U is applied, time delay t begins. When time delay t is complete, relay contacts R change state for time delay t. This cycle will repeat until input voltage U is removed. Trigger switch is not used in this function.

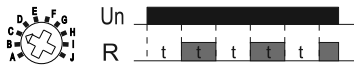

## D: Repeat Cycle (Starting On)

When input voltage U is applied, relay contacts R change state immediately and time delay t begins. When time delay t is complete, contacts return to their shelf state for time delay t. This cycle will repeat until input voltage U is removed. Trigger switch is not used in this function.



## E: Off Delay (S Break)

Input voltage U must be applied continuously. When trigger switch S is closed, relay contacts R change state. When trigger switch S is opened, delay t begins. When delay t is complete, contacts R return to their shelf state. If trigger switch S is closed before time delay t is complete, then time is reset. When trigger switch S is opened, the delay begins again, and relay contacts R remain in their energized state. If input voltage U is removed, relay contacts R return to their shelf state.

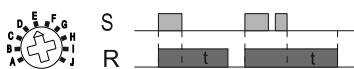

## F: Single Shot

Upon application of input voltage U, the relay is ready to accept trigger signal S. Upon application of the trigger signal S, the relay contacts R transfer and the preset time t begins. During time-out, the trigger signal S is ignored. The relay resets by applying the trigger switch S when the relay is not energized.

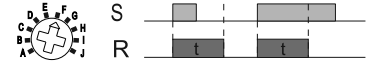

## G: Single Shot Trailing Edge (Non-Retriggerable)

Upon application of input voltage U, the relay is ready to accept trigger signal S. Upon application of the trigger signal S, the relay contacts R transfer and the preset time t begins. At the end of the preset time t, the relay contacts R return to their normal condition unless the trigger switch S is opened and closed prior to time t (before preset time elapses). Continuous cycling of the trigger switch S at a rate faster than the preset time will cause the relay contacts R to remain closed. If input voltage U is removed, relay contacts R return to their shelf state.



## H: On/Off Delay

Input voltage U must be applied continuously. When trigger switch S is closed, time delay t begins. When time delay t is complete, relay contacts R change state and remain transferred until trigger switch S is opened. If input voltage U is removed, relay contacts R return to their shelf state.



## I: Latching relay

Input voltage U must be applied continuously. Output changes state with every trigger switch S closure. If input voltage U is removed, relay contacts R return to their shelf state.

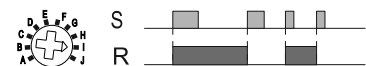

## J: Pulse generator

Upon application of input voltage U, a single output pulse of 0.5 seconds is delivered to relay after time delay t. Power must be removed and re-applied to repeat pulse. Trigger switch is not used in this function.

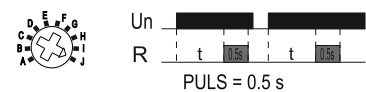

PULS = 0.5 s

## Dimensions(mm)

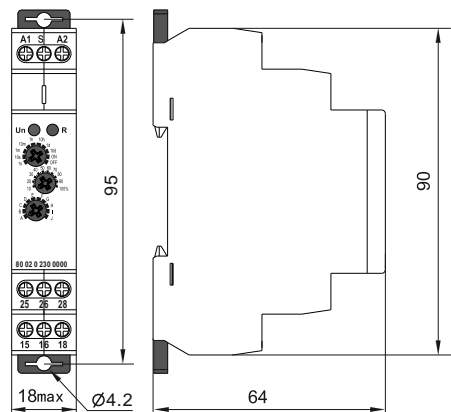

## Setting instructions

	Knob 1: delay gear setting, "s" for second, "m" for minute, "h" for hour, "d" for day, "ON" for relay action (15-18/25-28 closed), "OFF" for relay open (15-18/25-28 open).
	Knob 2: fine adjustment of delay time, 10% ~ 100% adjustable.
<p>Delay time = knob 1 × knob 2.</p> <p>Example 1: it needs to be set for 5 seconds. You can set knob 1 to 10s, knob 2 to 50%, and delay time = 10s × 50% = 5s.</p> <p>Example 2: it needs to be set for 8 minutes. You can set knob 1 to 10m, knob 2 to 80%, and delay time = 10m × 80% = 8m.</p>	



**Disposal of Electrical Waste**  
All electrical waste should be disposed of in compliance with current WEEE regulations.



**Caution**  
The products must be installed by qualified electricians. All and any electrical connections of the product shall comply with the appropriate safety standards.